



FIRENZO
WOODFIRES

Please read this booklet and keep for future reference for the safe installation and operation of your:

VIKING AG

DRY MODEL

AG = Clean Air

FREESTANDING WOODBURNER

All installations must be in accordance with these instructions. Consult with the building authority having jurisdiction to determine the need for a permit prior to commencing the installation. Failure to follow these instructions may also void your fire insurance and warranty.



Please complete and return your warranty registration card which is enclosed.

INDEX

<i><u>Page No:</u></i>	<i><u>Item No:</u></i>	<i><u>Topic:</u></i>
3	1	Warnings
4	2	Installation Responsibilities
4	3	Floor Protector Requirements
5	4	Installation Clearances
6	5	Assembly Instructions
7	6	Flue Installation
8		Minimum Height of Flue System
		Exit
9		Triangle Baffles

Edited 24/2/2010

1. WARNINGS

THIS APPLIANCE SHOULD BE MAINTAINED AND OPERATED AT ALL TIMES IN ACCORDANCE WITH THESE INSTRUCTIONS.

The **Viking AG** is tested to N.Z. Standards AS/NZS 2918:2001.

If this heater is incorrectly installed a house fire may result. For your safety follow the installation instructions carefully.

Do NOT connect the heater to a chimney serving another appliance.

Although the exterior of the heater may appear cool, contact with the unit may cause burns, warn children and others of the possibility of injury should they touch the heater.

Do NOT dry clothing or unseasoned wood directly in contact with the heater.

Keep all household combustible materials at least 600mm away from front of the heater. This includes clothing, furniture, wood, newspaper, plastic, matches, etc.

DO NOT USE FLAMMABLE LIQUIDS OR AEROSOLS IN THE VICINITY OF THIS APPLIANCE WHEN IT IS OPERATING.

Use caution when reloading with fuel. Do NOT attempt to load fuel into the heater when the fire inside the stove is at or near its peak.

Do NOT burn large quantities of paper or combustible material that would create an extremely hot/quick fire.

Do NOT burn highly coloured paper or brochures (junk mail).

USE ONLY DRY WOOD. AVOID BURNING WET OR GREEN WOOD.

THE USE OF SOME TYPES OF PRESERVATIVE TREATED WOOD AS A FUEL CAN BE HAZARDOUS.

TIMBER TREATED WITH COPPER CHROMIUM AND ARSENIC TYPE PRESERVATIVES WILL LEAVE TOXIC RESIDUES IN THE ASH, FIREBOX OR WITHIN THE FLUE; TIMBER OFFCUTS FROM BUILDING CONSTRUCTION WILL OFTEN CONTAIN BORIC SALTS. THE COMBUSTION OF THIS MATERIAL OVER PROLONGED PERIODS CAN PRODUCE ADVERSE EFFECTS ON REFRACTORY LINING IN SOLID FUEL APPLIANCES. EMISSION OF POISONOUS GASES CAN ALSO BE EXPERIENCED WITH THE BURNING OF TREATED WOOD.

Driftwood with salt content will also cause rapid deterioration of the heater and should not be used.

2. INSTALLATION RESPONSIBILITIES

WARNING: THE APPLIANCE AND FLUE SYSTEM SHALL BE INSTALLED IN ACCORDANCE WITH AS/NZ 2918 AND THE APPROPRIATE REQUIREMENTS OF THE RELEVANT BUILDING CODE OR CODES.

ANY MODIFICATION OF THE APPLIANCE THAT HAS NOT BEEN APPROVED IN WRITING BY THE TESTING AUTHORITY IS CONSIDERED TO BE IN BREACH OF THE APPROVAL GRANTED FOR COMPLIANCE WITH AS/NZS 4013.

CAUTION: MIXING OF APPLIANCE OR FLUE-SYSTEM COMPONENTS FROM DIFFERENT SOURCES OR MODIFYING THE DIMENSIONAL SPECIFICATION OF COMPONENTS MAY RESULT IN HAZARDOUS CONDITIONS. WHERE SUCH ACTION IS CONSIDERED, THE MANUFACTURER SHOULD BE CONSULTED IN THE FIRST INSTANCE.

Strict adherence to these instructions will meet these standards. Any variation from these installation instructions or any doubt about them must be checked against the requirements of the Standards.

Please leave this manual with the owner when installation is complete.

3. FLOOR PROTECTOR REQUIREMENTS

The heater should always be installed on top of its base due to high temperatures sustained over long periods. The base must be anchored to both the floor protector and the floor for seismic restraint. Anchor points are provided in the base.

If the heater is installed on or within 500mm of a heat sensitive floor, **then an ash floor protector using a minimum of 6mm thick tiles will be required.** This floor protector shall extend under the appliance and not less than 300mm beyond the front of the fuel loading or ash removal openings. The width of the floor protector shall be not less than the width of the appliance, and shall extend not less than 200mm from each side of the fuel loading or ash removal openings unless it forms an abutment with a wall or heat shield at a lesser distance.

Where the floor protector consists of a number of components, it shall include a continuous layer of heat-resistant material extending under the appliance to the perimeter of the floor protector. All joints shall be fixed to prevent accidental separation, and shall be sealed to prevent any spilt ash or embers contacting any heat sensitive material.

4. INSTALLATION CLEARANCES

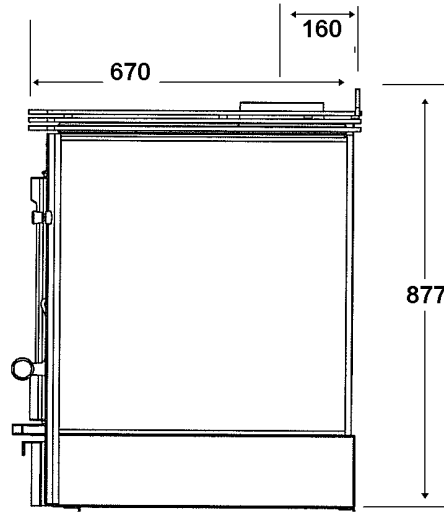
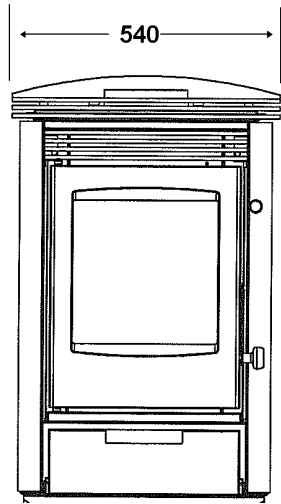

Firebox Size: Height 340mm
 Width 320mm
 Depth 500mm

Flue Size: 150mm
 Heating Area estimate 200sqm

CLEARANCES	A	B	C	D	E	F	G	H	J	K	L	M	N	O
WITH FLUE SHIELD	100	320	300	120	50	260	590	350	780	1040	1280	1060	780	410

Clearances are shown with an ash floor protector using 6mm ceramic tiles

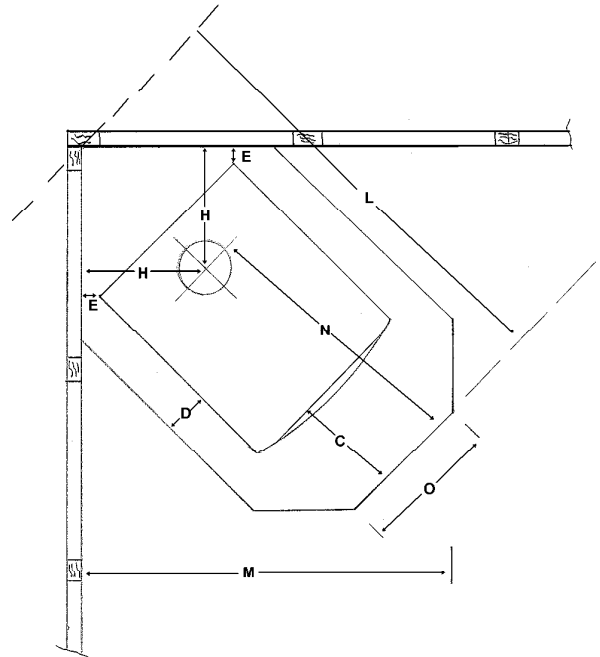
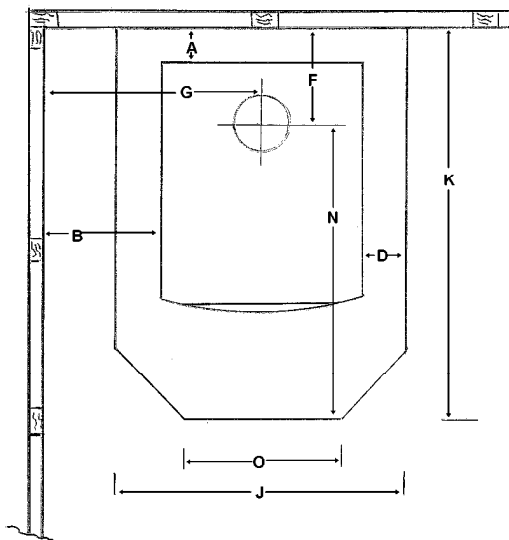

5. ASSEMBLY INSTRUCTIONS

1. Remove all outer packaging and timber.
2. Remove slotted steel top plates from rear of heater and cast iron top plates from inside the heater and carefully set aside, taking care not to scratch or damage the paint finishes.
3. Position unit onto floor protector ensuring it complies with the clearances as shown in section 4 on page 5.
DO NOT ATTEMPT TO LIFT THE HEATER BY THE GRANITE ASHLIP.
4. Make sure the flat and triangular baffle bricks and the stainless steel flue gas deflectors are correctly sited as per diagram on page 9.
5. Install the rear cast iron plate and then the front cast iron plate onto the rope seals around the top of the firebox and ensure they are bedded down well. Lifting lugs are positioned onto the sides of the casting, taking care not to catch fingers under the plates.
6. Assemble and install the flue as per instructions (page 7 & 8).
7. A flue shield must be fitted; the minimum requirement is for a single skin, semi-circular, stainless steel flue shield with a reflective inner surface 1200mm high. This should be installed so that the bottom edge of the flue shield is 20mm from the top surface of the heater and spaced off the flue pipe by approximately 35mm.
8. Secure the fire to the floor by using appropriate fastenings through the holes provided in the rear of the base plate. This is a New Zealand Standard 2918 requirement due to NZ being earthquake prone.
9. Carefully position the main slotted steel painted top panel onto the heater, there are locating lugs on the underside that fit into the indents on the cast iron tops that ensure it is correctly positioned. Slide in the rear infill top plate behind the flue and the curved top plate locates into the lugs onto the back edge.
10. Fit door knob with spacer as per drawing shown herewith. -

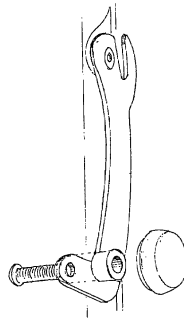

6. FREESTANDING FLUE SYSTEM INSTALLATION INSTRUCTIONS

1. Position heater on floor protector ensuring all heater clearances are correct as per clearances on page 5.
2. Once the location is confirmed, the appliance and floor protector shall be fixed to the floor itself (refer to page 6 & 7).
3. Extend a plumb line from the centre of the fire flue pipe spigot to the ceiling. Mark position on ceiling and roof.
4. Trim hole and nog as required ensuring that a 25mm safe clearance between combustible materials and flue components is maintained. Fix with non combustible spacers and screws or clouts on all four sides.
5. Cut and frame (when required) an opening in the roof, position the outer casing through the roof until it is flush with the under side of the ceiling, making sure as with the ceiling there is a 25mm safe clearance between non-combustible materials and the flue components. Fix as in step 4.
6. Fix appropriate flashing around outer casing to the roof to ensure a weatherproof seal.
7. Assemble flue pipe sections ensuring all seams are in line, the assembly is straight and crimped. Ends are pointing downwards. Fix each joint with three stainless rivets or self-tapping screws.
8. Place ceiling plate with folded edges upwards over heater spigot.
9. Position the flue pipe into the heater spigot. The flue pipe can either lowered from the top as a single unit or fed up from the room a length at a time, ensuring that all joints are fixed properly.
10. Slide the inner casing into place, between the outer casing and the flue pipe.
11. The flue pipe must extend 200mm above the outer casing.
Note: Extra lengths of flue pipe, inner and outer casing may be required to achieve the minimum clearance from the roof.
12. Slide top spreader over flue pipe down into outer and inner casing and tighten.
13. Slide cowl over flue pipe until it rests on spreader. Secure with rivets or self-tapping screws.
14. Fit rainhat. Do not fasten as it must be removable for flue pipe cleaning.
15. Fix ceiling plate to ceiling maintaining an even gap all around flue pipe.
Note: Ensure ceiling plate is spaced off from the ceiling with ceramic spacers supplied.

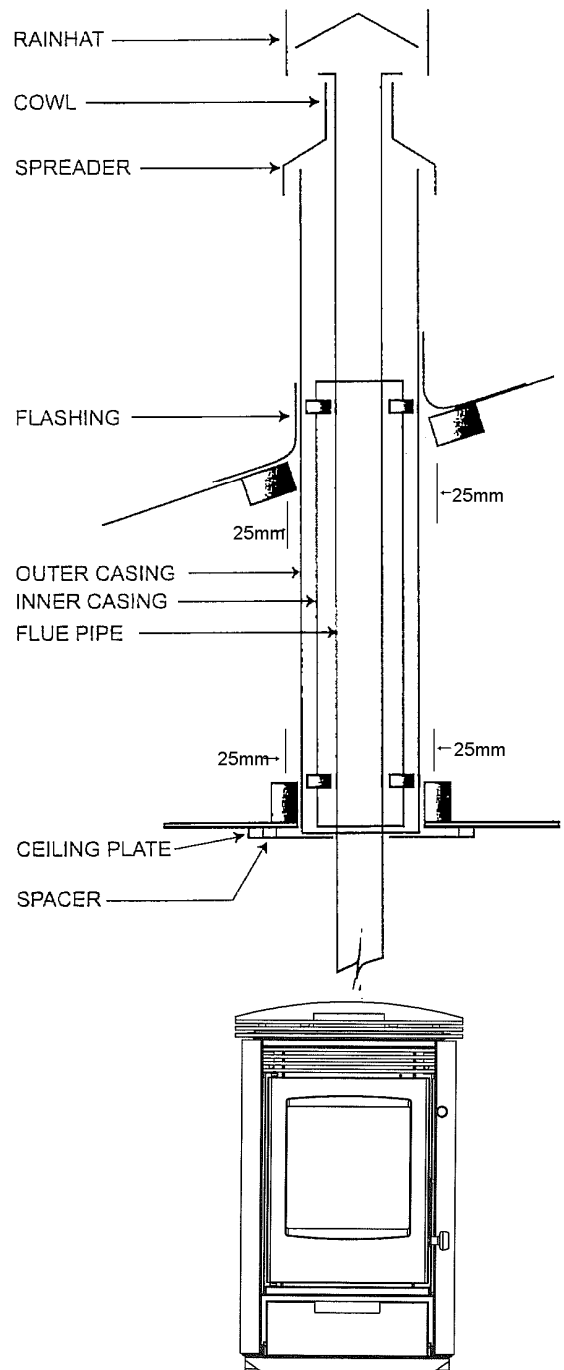

CAUTION: Mixing of appliance or flue system components from different sources or modifying the dimensional specifications of components may result in hazardous conditions. Where such action is considered the manufacturer should be consulted in the first instance.

WARNING: The appliance and flue system shall be installed in accordance with AS/NZS 2918:2001 and the appropriate requirements of the relevant building code or codes.

MINIMUM HEIGHT OF FLUE SYSTEM OUTLET

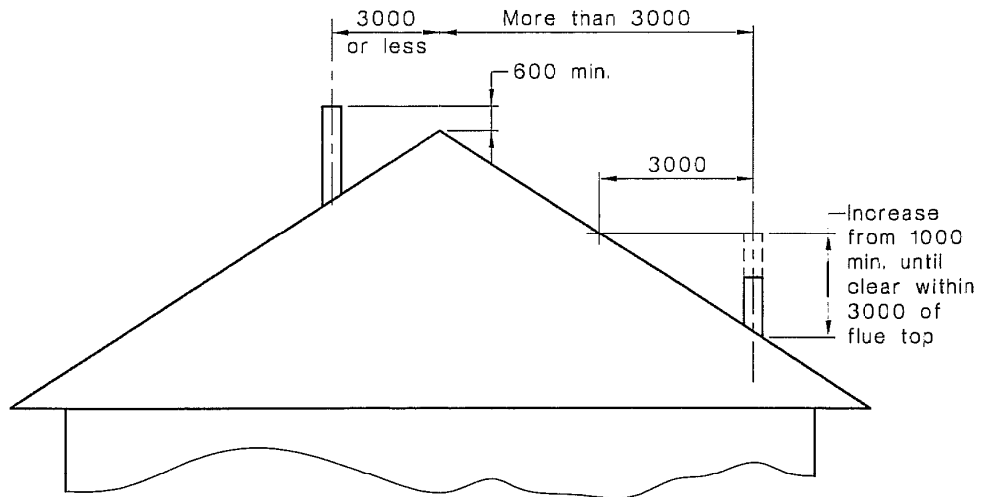
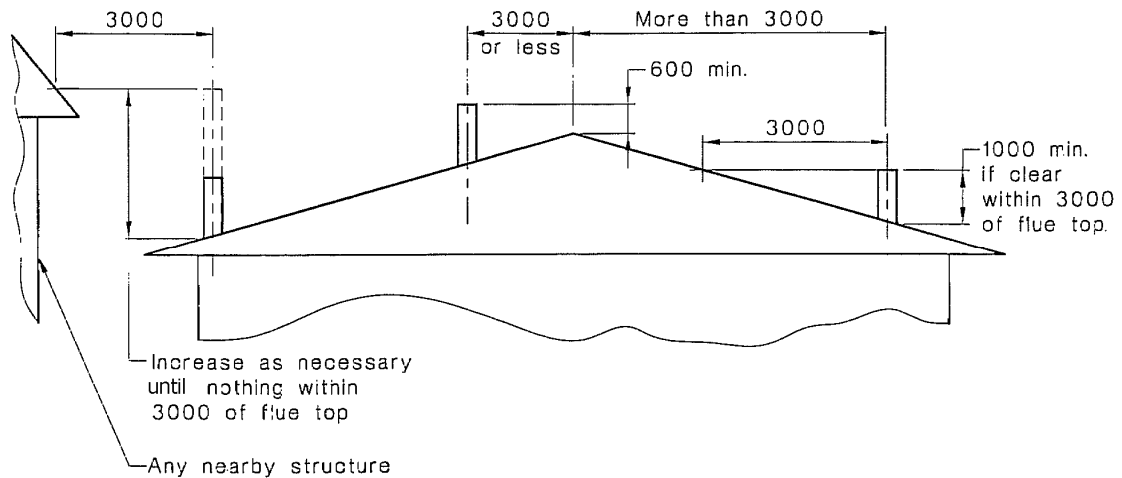

DIMENSIONS IN MILLIMETRES

NOTES:

1. The flue pipe shall extend not less than 4.6m above the top of the floor protector.
2. The flue cowl must be at least 600mm above the highest point of the roof if within 3 metres of it, or 1 metre above the roof penetration if more than 3 metres from the ridge.
3. No part of the building, or any adjacent building may be in or above a circular area of a horizontal radius of 3 metres from the flue exit.

IMPORTANT

UPON INSTALLATION CHECK THAT THE TRIANGULAR BRICK ON TOP OF THE BAFFLES IS PLACED AS SHOWN.

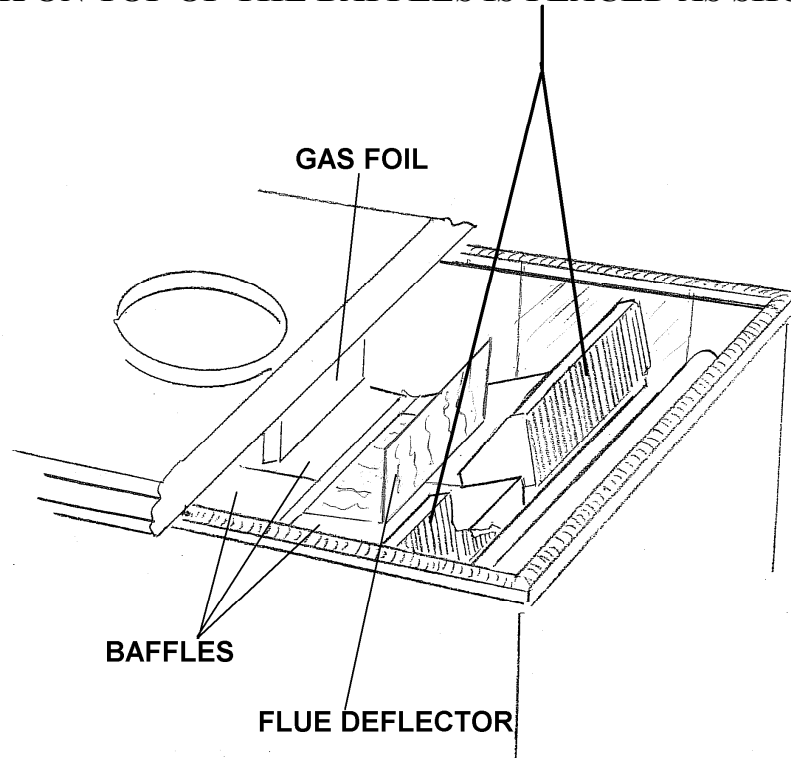

FIRENZO

WOODFIRES

BY
Hewitsons Limited

Manufacturers of:

Lady Kitchener

Bronte

Coaster

Contessa

Dante

Royale

Zealandia

Athena

Forte

Aqualux

68 Austin Street
PO Box 3231
Onekawa
Napier
Phone: 06 8438260
Fax: 06 8430505

Email: hothouse@firenzo.co.nz

Web: www.firenzo.co.nz